

Greddy
BLOW OFF VALVE
TYPE-RS
ADAPTER KIT

BRS-610 GDB

Instruction Manual

Please read the manual carefully before installing and using this product.

This product is for off road use only.

MAKE	MODEL	CHASSIS	ENGINE	YEAR
SUBARU	IMPREZA WRX	GDB	EJ20/EF25	2002 - 2005

*USDM

APPLICATION : Recirculation Type

※ Parts necessary for recirculation are included.

	<p>Important This kit is designed for the vehicle specified above. Please do not attempt to install this kit on other application.</p>
---	---

SAFETY INFORMATION

Important

- This Manual will explain the proper installation procedure of this product.
Please read this manual carefully.
- This manual was created considering the vehicle to be completely factory spec.
- While using this product, please keep this manual to use as a reference.
- The notation shown below is used through out this manual.



Caution

This notation will indicate the important procedures and instructions to prevent accidents and injury.



Warning

This notation will indicate the important procedures and instructions to prevent life treating accidents and injury.

- ◆ If sub injectors are used make sure to mount the injectors after the blow off valve between the blow off valve and the throttle body.
- ◆ On some applications, there are possibilities of engine stall if the air is released out to the atmosphere.

It is recommended to re-circulate the air back in to intake system before the turbo in-let



Caution

DO NOT disassemble or mishandle this product.

This will cause the product failure and may damage the engine.

Important

1. This product is for off road use only.

- This product is legal for sale or use in CA only on vehicles, which may never be driven on a public highway. Check your state and local laws regarding the use of any performance products.

2. Installation of this product should be performed by an experienced mechanic.

- Special tools and modification skills are necessary for the installation of this product.

3. Inspect the vehicle before the installation of this product.

- Inspect the vehicle and make sure that there are no problems with the vehicle before installation.

4. Do not use this product for purpose other what is intended for.

- Damage due to modifications or misuse of this product will void any warranty.

Important

1. Disconnect the negative terminal of the battery before installation
2. Make sure the engine room has cooled down before installation.
3. Removal and disassemble caution

Please follow the basic manufacturer's recommendation

- Make sure to clean the parts that are reused and replace any parts that are damaged.
4. Installation and reassembly caution
 - Clean the parts thoroughly before installing the parts.
 - Make sure to replace gaskets with new part.
 - Please refer to the torque spec chart for the proper torque specs for the bolts and nuts.

Jacking and lifting precautions



Caution

- When Jacking up the front or rear of the vehicle, please make sure to lift the vehicle up at the proper jack points and use safety stands and Wheel chocks.
- When Lifting the vehicle, ensure that the front and rear of the vehicle are well balanced at the proper lift points.

Important



Caution Make sure to check the installation before operating the vehicle.



Caution Before starting the engine, make sure that there are no flammable items around the exhaust system and in the engine room.



Warning Start the engine in a well-ventilated area.

Although we have taken all the possible measures to provide the highest quality products, we will not be responsible for any damage, or accidents caused by improper use, incorrect installation.

GReddy Performance Products, Inc.

PARTS LIST

1. BLOW OFF VALVE	×1	9. THREE WAY FITTING 12φ	×1
2. ADAPTER FLANGE	×1	10. FACTORY GASKET	×1
3. RETURN TUBE	×1	11. BLOW OFF GASKET	×1
4. HOSE ATTACHMENT 32φ	×1	12. ZIP TIES	×7
5. 34φ PLUG	×1	13. EMBLEM	×1
6. SILICONE HOSE 32φ	×1	14. FLAT BOLT	×1
7. RUBBER HOSE 12φ × 800mm	×1	15. BOLT+WASHER	×2
8. HOSE BAND #20	×3		

PARTS LIST

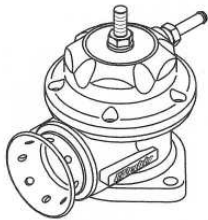

1

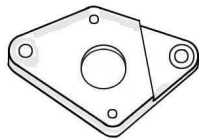

2

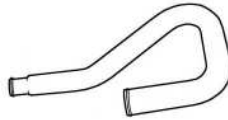

3



4

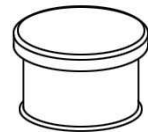

5



6

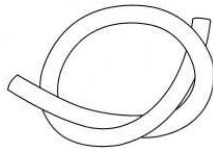

7

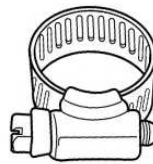

8

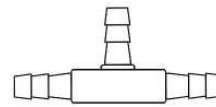

9

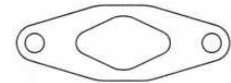

10

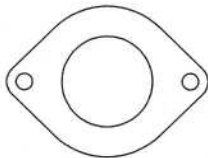

11



12



13



14

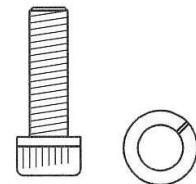

15

Installation

- (1) Disconnect the blow by hose and remove the blow by tube off from the intercooler.
- (2) Disconnect the Air Bypass Valve hose and remove the valve.

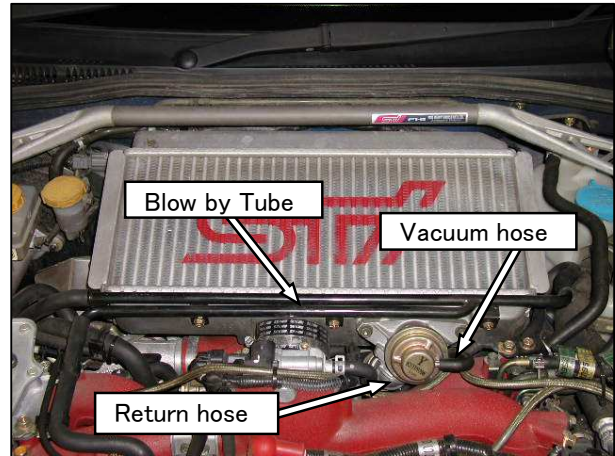

- (3) Disconnect the turbo outlet hose and throttle hose and remove the intercooler.

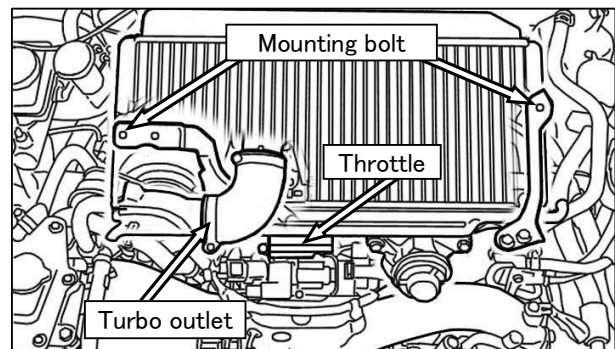

- (4) Remove the left blow by hose. Cut the provided 12 ϕ rubber hose to 650mm and install it using the provided three way fitting to the right blow by hose as shown.

※ To prevent the hose from interfering with the throttle, route the hose over the throttle body and secure the hose to the intake manifold with the provided zip ties.

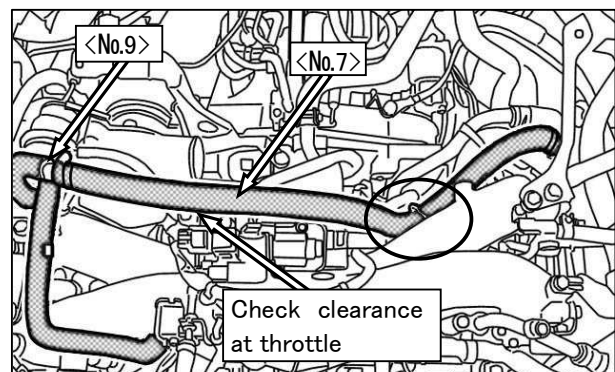

※ Secure the hose ends with the provided zip ties.

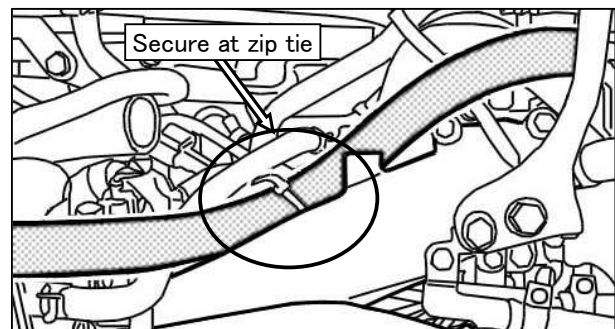

- (5) Install the adapter flange to the intercooler using the provided gasket and bolts as shown.

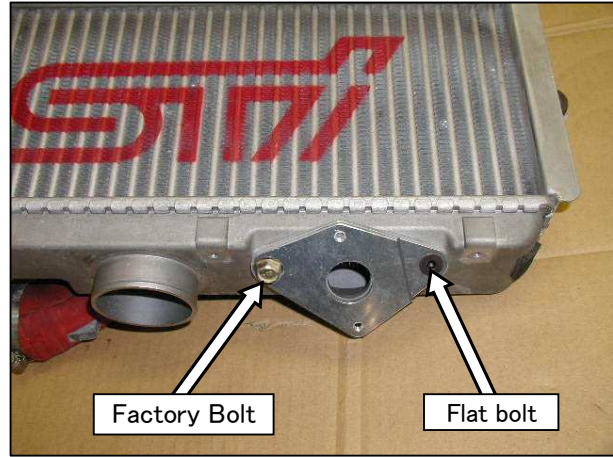

《Venting out to atmosphere Type》

- (1) Install the provided 34Ø plug to the air by pass hose and use factory hose band.
- (2) Install the GReddy Blow Off Valve using the provided gasket and bolts.
- (3) Reinstall the intercooler and connect the turbo out let hose and throttle body hose.
- (4) Reconnect the vacuum hose to the top of the blow off valve and place the emblem on the top cover.

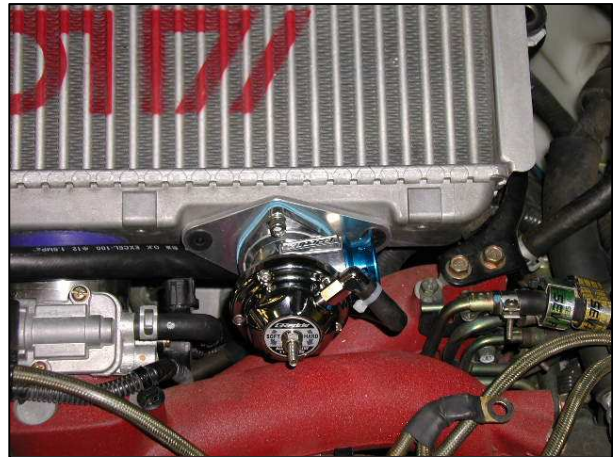

《Recirculation Type》

- (1) Remove the factory air bypass hose.
 - ※ When removing the hose mark the suction tube side of the hose.
- (2) Cut the air bypass hose as shown and reinstall the hose to the suction tube.

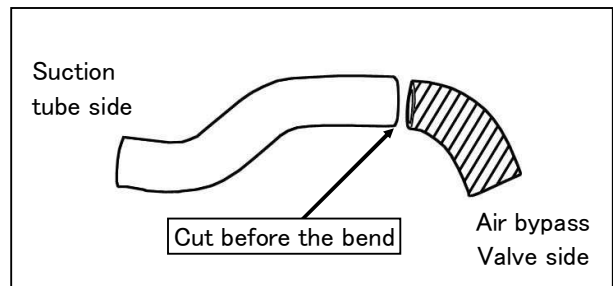

- (3) Install the provided return pipe to the cut air bypass hose as shown.
- ※ Route the return pipe under the left intercooler bracket as shown.

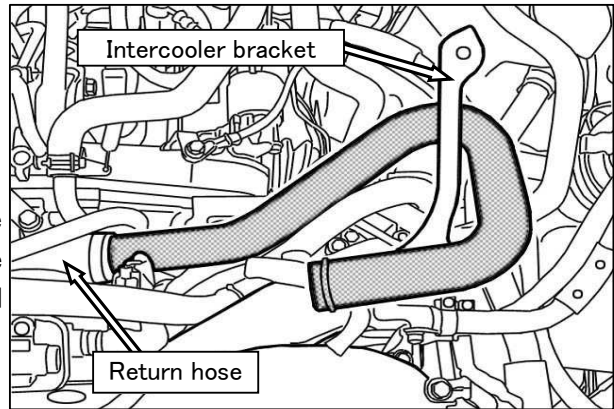

- (4) Remove the discharge funnel off from the blow off valve and install the valve on to the intercooler using the provided gasket and valve.
- ※ The attachment can be easily turned off. Make sure not to damage the o ring.

- (5) Reinstall the intercooler and connect the turbo out let hose and throttle body hose.

- (6) Connect the return pipe to the blow off valve with provided 34Øsilicone hose.

- (7) Reconnect the vacuum hose to the top of the blow off valve and place the emblem on the top cover.



Starting the engine

- (1) Inspect the installation. Reconnect the negative terminal of the battery and start the engine.
- (2) Check and make sure that there no air leaks, clearance problems or irregular sound.
- (3) Lightly rev up the engine couple times to check if the blow off valve is operating.

Adjustment after installation

If irregular idle or engine stall occurs, loosen the M6 lock nut and turn the adjustment screw to **HARD** until the problem is eliminated.

After the adjustment, tighten the lock nut to secure the setting.

- ※ The adjustment is preset to the softest position form factory. Do not turn it further out that this position.
- ※ Make sure to loosen the lock nut before making adjustment. Turning the adjusting screw without loosening the lock nut will strip out the top housing.
- ※ When the adjustment screw is turned in, the stock of the valve decreases. Screwing it in too far will affect the proper operation of the valve.

When venting the outlet to the atmosphere, depending on the application, the airflow meter voltage can drop enough to stall the vehicle when the blow off valve is discharged.

If adjustment of the top screw cannot prevent the engine stall, install e-Manage system and use the Anti Engine Stall feature or reroute the discharge outlet back into the intake system after the airflow meter.



Warning

If the engine stalls while operating the vehicle, the steering and the Brakes will not operate properly and can be very dangerous.

How to change the Attachment

The attachment on the GReddy Type RS is interchangeable with discharge funnel or hose attachment.

To remove the attachment, turn it counter clock wise, and to install turn it clock wise.

When changing the attachment, place the O-ring to the attachment being installed and tighten until the attachment flange meets the blow of body.

- ※ Apply silicone grease before reinstalling the O-ring.
- ※ O-ring will not require excessive force to seal properly, so please be careful not to over tighten the attachment.

