

Reddy®

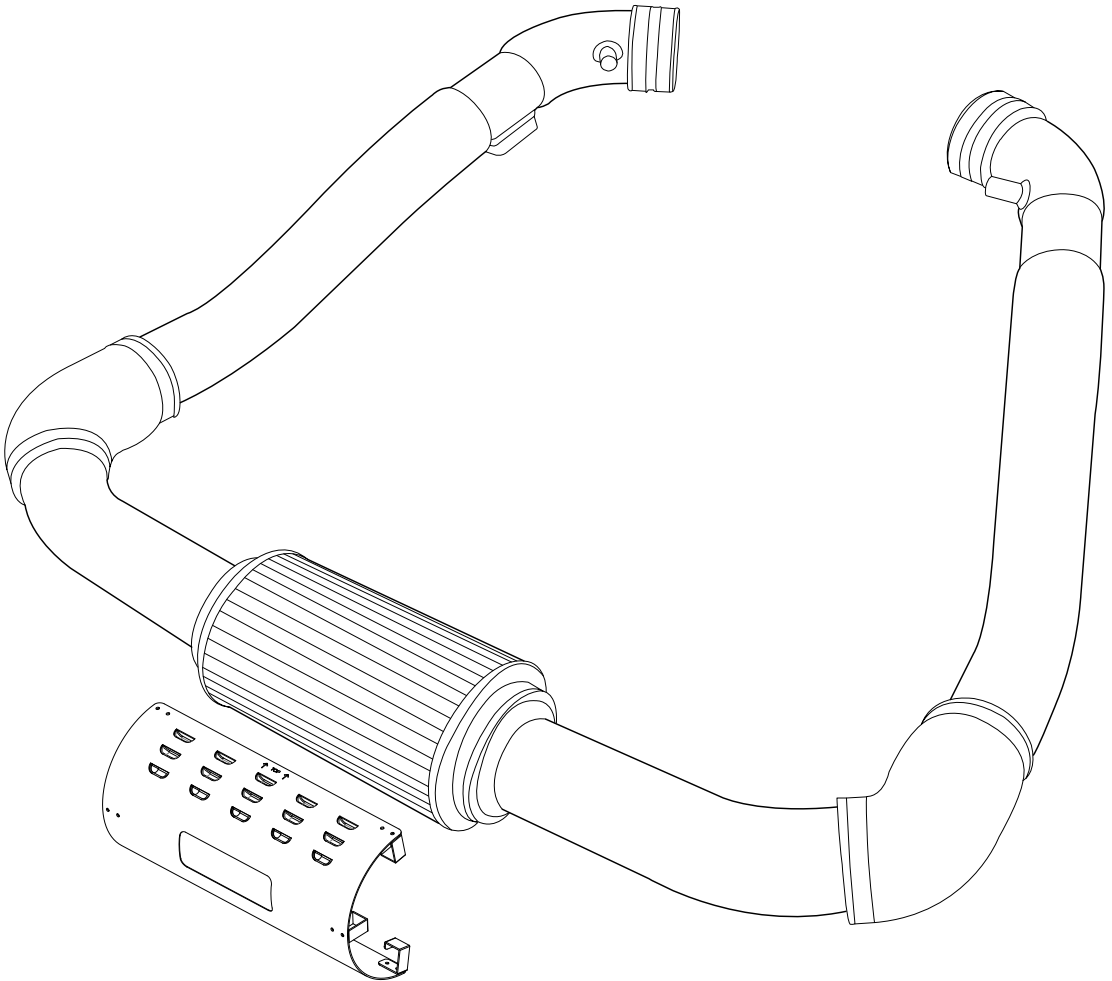

* Optional (12529002)

Instruction Manual P/N: 12529001

Make: **Infiniti** Model: **G37** Year: **2008-2011** Engine: **V6-3.7L**



- Please read the entire instruction manual before proceeding.
- Ensure all components listed are present.
- If you are missing any of the components, call customer support at 949-588-8300.
- Ensure you have all necessary tools before proceeding.
- Do not attempt to work on your vehicle when the engine is hot.
- Disconnect the negative battery terminal before proceeding.
- Retain factory parts for future use.

Label	Qty.	Description	Part Number
A	1	Pro Dry S Air Filter	61-90126
B	1	Intake Tube 1	05-T3016P1 (Pol)
C	1	Intake Tube 2	05-T3016P2 (Pol)
D	1	Intake Tube 3	05-T3016P3 (Pol)
E	1	Intake Tube 4	05-T3016P4 (Pol)
F	2	Bracket	05-T3016B5
G	2	Reducer Coupling	05-01116
H	2	Straight Coupling	05-00417
I	4	Clamp, #44	03-50019
J	4	Clamp, #48	03-50007
K	2	2" Hose (5/8" ID)	05-00069
L	2	Split Lock Washer	03-50062
M	2	Isolation Mount	03-50022
N	5	Flat Washer	03-50043
O	7	Hex Nut	03-50059
P	2	Hex Head Screw (lrg)	03-50175
Q	4	Cheese Head Screw	03-50034
R	2	MAS Gasket	05-00631
S	1	Bracket	05-T3016B6
T	1	Hex Head Screw (sml)	03-50057
U	1	Splash Shield	12529002 (NOT INCLUDED)

Installation will require the following tools:

Flat head & Phillips screwdriver, Vice grip, Pliers, 8mm socket, 10mm socket, Ratchet & 5/16 nut driver.

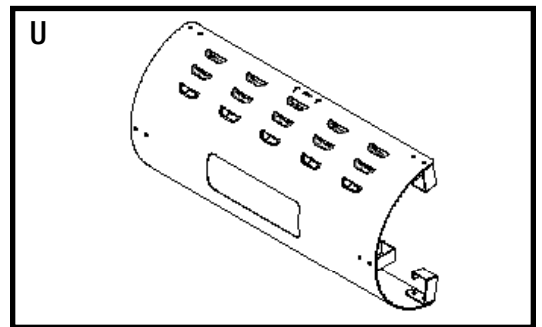
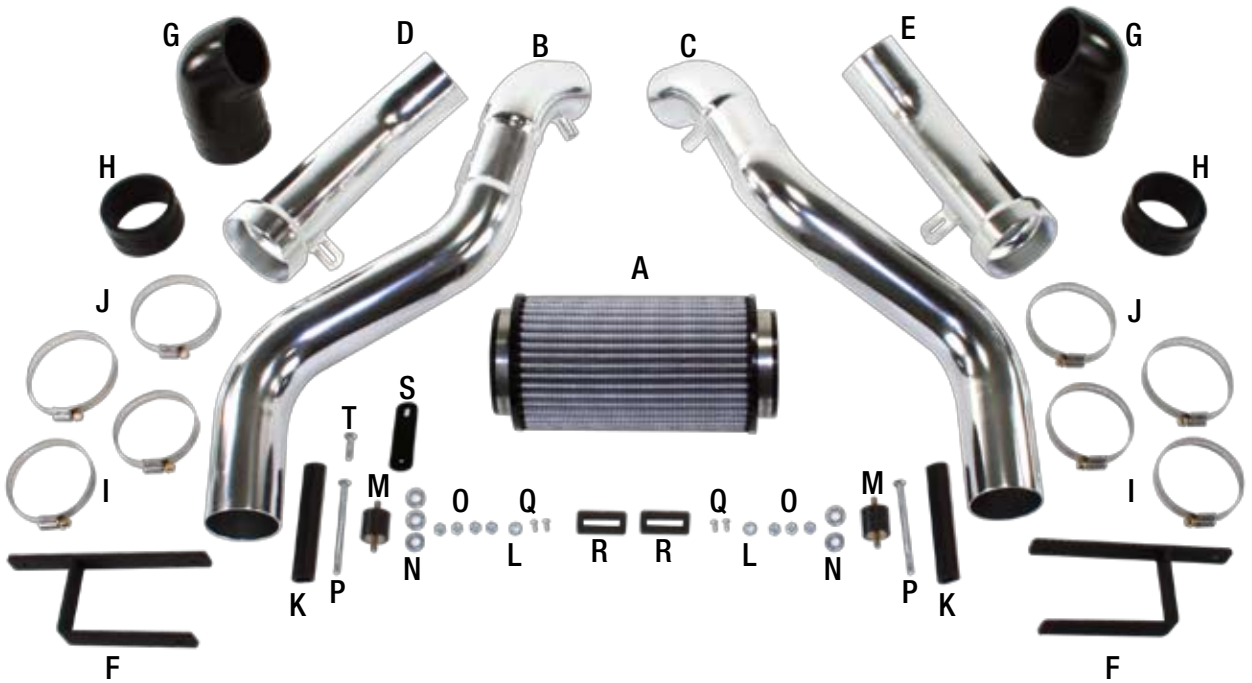

Note: Legal in California for use on race vehicles only. The use of this device on vehicles used on public streets or highways is strictly prohibited in California and others states that have adopted California emission regulations.

**Figure A****Refer to Figure A for steps 1-6**

Step 1: Remove the engine cover fasteners (1) and remove the engine cover.

Step 2: Loosen the clamp securing the intake tube to the throttle body. (2)

Step 3: Remove the airbox mounting bolt. (3)

Step 4: Unplug the mass airflow sensor (MAF) sensor wiring harness. (4)

Step 5: Disconnect the crankcase breather from the intake tube. (5)

Step 6: Remove the intake tube and airbox as one piece. (Some force is required to release the airbox from the mounting grommets).



Figure B2

Figure B

Refer to Figure B for steps 7-12

Step 7: Remove the retaining clips from the top of the front bumper. (6)

Step 8: Remove the 10mm bolts on the inside of the fenders. (Fig.B2)

Step 9: Remove the clip from the inside of the fender well.

Step 10: Remove the two 10mm bolts on the edge of the bumper on the inside.

Step 11: Remove the bolts from under the belly pan which connects the belly pan to the bumper.

Step 12: Remove the bumper.

**Figure C****Refer to Figure C for steps 13-15**

Step 13: Remove the air scoop mounting bolt and remove the scoop through the engine side of the vehicle.

Step 14: Loosen the horn mount (7) and adjust to accommodate the new intake tube.

Step 15: Remove the MAF sensors from the OE intake housings and install them on the new intake tubes using the supplied foam gasket (R) and screws (Q).

**Figure D****Refer to Figure C & D for steps 16-20**

- Step 16: Install the angled couplings (G) through the opening of the core support with the long side towards the engine bay and loosely install clamps. (Fig.C)
- Step 17: Install the straight couplings onto both throttle bodies with clamps.
- Step 18: Replace the OE crankcase breather hose with the supplied crankcase breather hose. (K)
- Step 19: Install the Takeda intake tubes and secure with the provided straight couplers and clamps.
- Step 20: Connect the MAF harness to the MAF sensors.



Refer to Figure E for steps 21-24

Step 21: Install the h-shaped tube mounting brackets onto the bumper brace in front of the radiator.

Step 22: Install the isolation mount onto intake tubes using the provided hardware.

Step 23: Loosely install the air filter on the intake tubes and adjust the tubes and filter prior to tightening the clamps and isolation mounts.

Step 24: Verify all clamps and mounting hardware is secure.



Figure F

Refer to Figure F & B for step 25

Step 25: Install the bumper by repeating steps 7 through 12 in reverse.

Your installation is now complete.

Pro DRY S Air Filter



P/N: 61-90126

Shield

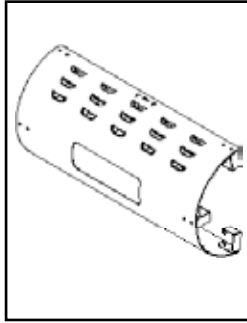

P/N: 12529002

To purchase any of the items above, view airflow charts, dyno graphs, photos, and video; please go to Greddy.com.

Page Left Intentionally blank

***GR*Reddy®**

***GR*Reddy Performance Products**

9 Vanderbilt, Irvine CA 92618

TEL: 949.588.8300 • Tech@greddy.com